

## Landscape graphs: Ecological modeling with graph theory to detect configurations common to diverse landscapes

Margot D. Cantwell<sup>1</sup> and Richard T.T. Forman

*Harvard University, Graduate School of Design, Cambridge, Massachusetts 02138, USA*

### Abstract

In view of the bewildering diversity of landscapes and possible patterns therein, our objectives were to see if a useful modeling method for directly comparing land mosaics could be developed based on graph theory, and whether basic spatial patterns could be identified that are common to diverse landscapes. The models developed were based on the spatial configuration of and interactions between landscape elements (ecosystems, land uses or ecotopes). Nodes represented landscape elements and linkages represented common boundaries between elements. Corridors, corridor intersections, and the matrix were successfully incorporated in the models. Twenty-five landscape graphs were constructed from aerial photographs chosen solely to represent a breadth of climates, land uses and human population densities. Seven distinctive clusters of nodes and linkages were identified and common, three of which, in the forms of a 'spider', 'necklace' and 'graph cell,' were in >90% of the graphs. These represented respectively the following 'configurations' of patches, corridors and matrix: (1) a matrix area surrounding or adjoining many patches; (2) a corridor bisecting a heterogeneous area; and (3) a unit in a network of intersecting corridors. The models also indicated that the connectivity or number of linkages for several common elements, such as fields and house clearings, was relatively constant across diverse landscapes, and that linear shaped elements such as roads and rivers were the most connected. Several additional uses of this graph modeling, including compatibility with systems dynamics models, are pinpointed. Thus the method is useful in allowing simple direct comparisons of any scale and any landscape to help identify patterns and principles. A focus on the common and uncommon configurations should enhance our understanding of fluxes across landscapes, and consequently the quality of land planning and management.

### Introduction

The apparent dissimilarity of landscapes with contrasting climate, land use and human density makes understanding the ecology of landscapes a challenge indeed. Yet deciphering patterns or specific configurations within land mosaics is critical, because fluxes of species, energy, and materials, and

landscape changes over time are spatially dependent (Levin 1976, Dykstra 1981, Forman and Gordon 1986, Gardner *et al.* 1989, Merriam 1990). Modeling of these complex systems must be a key component for enhancing ecological understanding.

The varied approaches to modeling heterogeneous landscapes (De Angelis *et al.* 1985, Baker 1989,

<sup>1</sup> Present address: Environmental Design and Management, P.O. Box 34110, Halifax, Nova Scotia B3J 3S1, Canada

Turner and Gardner 1991) include: (a) hexagonal packing models (Christaller 1933, Haggett *et al.* 1977); (b) general neutral models (Caswell 1976, Gardner *et al.* 1987, Milne *et al.* 1989); (c) percolation theory (Stauffer 1985, O'Neill *et al.* 1988, Gardner *et al.* 1989); (d) hierarchy theory (O'Neill *et al.* 1986, 1989); (e) fractal analysis (Burrough 1981, Milne 1988); (f) geometric models (Franklin and Forman 1987, Hansen *et al.* 1992); (g) neighborhood models (Shugart and Seagle 1985, Turner 1987a); (h) entropy information models (Godron 1966, Forman and Godron 1986); (i) various simulation models (Sklar *et al.* 1985, Turner 1988, Wiens and Milne 1989); (j) geographical information systems models (Burrough 1986, Johnson 1990, Burke *et al.* 1990); (k) cellular automata (Zeigler 1976, Couclelis 1985); (l) network models (Taaffe and Gauthier 1973, Haggett *et al.* 1977, Forman and Godron 1986, Forman 1991); (m) patch and corridor simulation models (Fahrig and Merriam 1985, Merriam 1990); and (n) patch dynamic models (Levin 1976, Pickett and White 1985). This array has produced impressive results. Yet no single approach successfully satisfies three key or minimal ecological criteria: (1) a focus on the spatial configuration of patches, corridors and matrix as basic elements of the landscape; (2) a focus on interactions of fluxes between elements; and (3) direct comparison of the first two characteristics at any scale in any landscape. Graph theory may provide a useful foundation from which to develop models that incorporate these three criteria.

Graph theory is an established modeling method used in a variety of disciplines to describe relationships between objects. A graph consists of a finite set of nodes (points, vertices), a finite set of linkages (edges, lines), and a rule that defines which edges join which pairs of vertices (Ore 1963, Harary 1972, Rouvray 1973, Wilson 1979). It is customary to represent a graph by means of a diagram, and refer to the diagram as the 'graph'. Unlike 'Euclidean' graphs with horizontal and vertical axes, graph theory graphs portray topological quantities, patterns and relationships. Common applications of graph theory include transportation route maps, molecular graphs in chemistry, and electrical circuit graphs. In ecology, aspects of graph theory have been used to analyze food webs, succession, phyto-

sociological structures, and other patterns (Levins 1975, Cohen 1978, 1990, Dale 1985, Roberts 1989, Bruce G. Marcot personal communication, Patrick Kangas personal communication). Only a small portion of the richness of graph theory will be used for the modeling of landscapes in this paper.

The application of graph theory to landscape ecology (Risser *et al.* 1984) may prove useful for reducing complex landscapes into an understandable set of spatial configurations, thus uncovering patterns of interaction or flow, and possibly creating a framework for the modeling of landscape fluxes. A partial analogy with chemical compounds may be helpful. All landscapes can be described as composed of patches, corridors and a matrix (*e.g.*, Forman 1979, Turner 1987b). When these are described by type, one recognizes wooded patches, stream corridors, hedgerows, etc., let's say analogous to atoms, such as carbon, hydrogen and oxygen. But what are the analogues to benzene rings and carboxyl groups? Are there widespread repetitive combinations of patches and corridors, independent of landscape type? If such structures or building blocks of a landscape can be determined, they should noticeably enhance our ability to analyze landscape fluxes and function.

Several approaches to understanding fluxes through a land mosaic relative to graph theory are possible. For example, connectivity usually focuses on corridors and networks, *i.e.*, channels of movement through space (Lowe and Moryadas 1975, Haggett *et al.* 1977, Forman and Godron 1984, Fahrig and Merriam 1985, Kosova *et al.* 1986, Henein and Merriam 1990). However, it should be possible to approach connectivity from the perspective of particular types of landscape elements, *e.g.*, woods and house clearings. Are there repetitive patterns in the number of connections to surrounding landscape elements independent of landscape type? Other approaches to understanding fluxes relative to graph theory briefly considered here include systems dynamics models (Odum 1983, Robertson *et al.* 1991), connectivity matrices (Taaffe and Gauthier 1973), and percolation theory (Gardner *et al.* 1989). Here we will explore the potential application of these approaches to the spatial configuration of patches, corridors and matrix in the landscape graph.

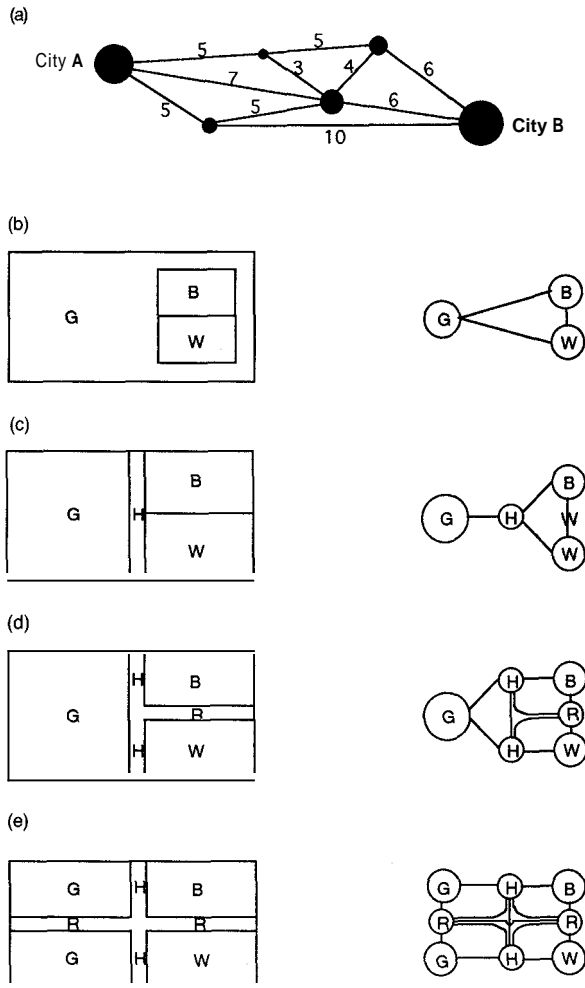

**Fig. 1.** Methods of drawing graphs. (a) Transportation graph with spatially-explicit linkage lengths representing distances (or time-distances) between cities, and node size indicating city size. (b) to (e) Landscape areas and their corresponding graphs; nodes (circles) represent elements (ecosystems, land uses) in the landscape, and linkages (lines) represent shared boundaries or points between elements. Landscape elements recognized are: G-grassland; B-bean field; W-woods; H-highway; and R-road. (b) Landscape graph of a matrix and two patches, recognizing the matrix as an element. (c) Landscape graph recognizing a corridor (highway) as an element. (d) and (e) Landscape graphs where a corridor network is represented as comprised of component elements, or lengths of corridor defined by intersections. (d) Landscape graph recognizing a 3-way or T-intersection. (e) Landscape graph recognizing a 4-way or X-intersection, and where one corridor axis predominates over the second.

Thus, the objectives of this paper are the following:

1. Develop a method that reduces inherently com-

plex landscapes to a common graph model, based upon the assumption that interactions between adjacent landscape elements are important.

2. Use this landscape graph to:

2.1. Identify common and uncommon patterns, if any, in the configuration of patches, corridors and matrix, independent of landscape type or location.

2.2. Determine the most and least connected element types in a landscape, and whether the number of elements adjacent to a given element type is independent of landscape context.

2.3. Pinpoint links between the graphs and other modeling approaches.

## 1. Development of the graph model

Graphs are comprised of (a) circles called 'nodes' (vertices, points, sites) that represent the spatial elements or parts of an object, and (b) lines known as 'linkages' (lines, edges, bonds) that connect nodes to represent a relationship between them.

Geography has long used graphs to portray the landscape. The common transportation route map describes cities as nodes, and cities that may be reached by transportation are connected by linkages (Taaffe and Gauthier 1973, Rugg 1979). Commonly the graphs are spatially explicit, with intercity distances illustrated by linkage length. City area or population may be illustrated by the size of the node (Fig. 1a). Vector mathematics may be applied to a spatially explicit graph to determine polar direction, and, if city size is illustrated, a gravity or other interaction model may be used to describe the influence of cities on each other. Both the ability to apply vector mathematics and the potential to apply models describing the influence of element size may be ecologically useful for landscape graphs. Therefore, in the graphs drawn, nodes are placed in the approximate center of elements, and node size reflects relative element size.

Common graph construction methods isolate the system being described from the background matrix. Molecular graphs, where atoms are nodes

and linkages represent atomic bonds, are an example. The matrix, or surrounding space in this case, is excluded from the description. Graphs used in geography normally utilize this technique as well (*e.g.*, the transportation system is isolated from its landscape setting) (Fig. 1a). When creating landscape graphs, this approach results in graphs that isolate individual systems from the landscape, rather than graphs of patterns and interactions over the total area. Therefore, in a graph of the landscape, the matrix must be a key element. An example of a graph which does not exclude the matrix is a food web graph of species use of resources (Sugihara 1983, 1984). In this graph, all resources are mapped as nodes, and linkages represent a relationship between nodes (resources) defined by a consumer species utilization. In analyzing landscapes we have taken a similar approach by mapping all landscape elements present as nodes (Fig. 1c) and not a priori designating one as the matrix to be excluded.

Corridors, as important elements or objects in a landscape, are also represented by nodes (Fig. 1c). Corridors frequently form interconnected networks across the landscape, *e.g.*, road systems and hedgerow networks. As linear shaped elements, different corridor types also intersect each other, *e.g.*, a road crosses a river. The modeling approach recognizes that, functionally, corridor networks are not a homogeneous landscape type, but rather highly connected individual elements. Where linear elements intersect, the corridor on one side of the intersection often has a different structure than on the other side (*e.g.*, a road intersecting a highway may increase the amount of traffic on the highway only in the direction towards the city). This is also the case where different linear element types intersect (*e.g.*, a stream intersecting a strip of woods may have a stony bottom upstream and a leaf-littered bottom downstream). For these reasons, each length of corridor, defined by its intersection with another length of corridor (whether of the same element type or not) is represented by a node (Figs. 1d and 1e).

Thus in the landscape graph model developed, nodes represent all landscape elements (local ecosystems, land use units, ecotopes, or biotopes),

whether patch, corridor or matrix. Linkages represent common boundaries between adjacent elements, or points where adjoining elements meet. It bears emphasis that linkages represent adjacency between elements, rather than specific routes or corridors on maps and photographs. Although empirical data are scarce, note that flux rates across different boundaries in a mosaic (*i.e.*, along different linkages in a graph) clearly differ. Thus birds and small mammals in a southern Ontario farmland moved much more between woods and hedgerow than between woods and field, woods and woods, or hedgerow and field (Wegner and Merriam 1979).

One of the difficult tasks in graph construction [and other modeling methods including geographic information systems (GIS)] is deciding how to represent intersections of linear elements. One common method is to recognize the intersection as a separate element, and insert a node at that point in the graph. Alternatively, graph linkages may be crossed over each other, without forming a node. If nodes are inserted to represent intersections, in many landscapes they permeate the graph and become as numerous as element nodes. Such a graph is more a description of juncture distribution than a portrayal of relationships and flows among landscape elements. Crossed linkages, on the other hand, clearly illustrate the network nature of linear elements. In a four-way or **X** intersection, linkages join the four corridor nodes together, illustrating all potential interactions. The result is two crossing linkages in the center of the four nodes, which is resolved by portraying the functionally dominant linkage (*e.g.*, more animal or traffic movement) as a continuous line and the other linkage as a 'broken' line (*i.e.*, with a small half circle) (Fig. 1e). If the crossed linkages are functionally similar or undetermined, both lines are 'broken'. [A three-way intersection is represented by three nodes (one for each corridor) that are all connected to one another (Fig. 1d).]

A final graph construction issue is scale, or determining what to include as elements (represented by nodes). Are home clearings shown individually or as suburban groups, and are individual adjacent fields differentiated or considered as one con-

tinuous cultivation landscape element? Is a large clearing with a narrow in the middle (hour-glass shaped) considered one clearing, or two clearings with a corridor? The scale of resolution of graphs must be tailored to the question posed; this is not unlike determining what grid cell size to use in GIS. Flexibility in distinguishing elements is considered desirable so that graphs may be constructed at any resolution of interest. In the graphs drawn for this paper, the ability to clearly differentiate relatively-homogeneous elements in an aerial photograph was the criterion utilized. For hour-glass shaped elements, if the element narrowed to one-third or less of its width, it was considered to be two elements connected by a corridor. The approach appeared useful for detecting and comparing patterns, no matter what the scale (*i.e.*, using aerial photographs of areas ranging from approximately 10 to 10,000 ha.).

The method developed is an exploratory approach that attempts to model and compare diverse landscapes. It allows the organization of the landscape as a whole to be modeled by incorporating, or illustrating how to handle, three attributes rarely encompassed in graph theory applications: the matrix, corridors, and corridor intersections. Four simple rules emerged from this methodology and are the basis of the graphs mapped and analyzed in this paper:

1. Each landscape element or ecosystem, including the surrounding matrix if present, is represented by a 'node' placed in the center of the element. Node size corresponds to element size.
2. A common boundary or point where two adjoining ecosystems meet is represented by a 'linkage'.
3. A graph may be constructed at any scale by identifying the elements to be included.
4. Corridor intersections separate individual corridor elements. Intersections are represented by linkages interconnecting the nodes.

Using this graph construction method, 25 landscape graphs were drawn on clear plastic sheets covering aerial photographs. Photographs were chosen from a diverse collection on the sole basis of representing a wide range of regions, climates, vegetation types, human population densities, and

land uses (see Appendix). Predominant land uses included forestry, pastureland, cultivation, suburbia, and 'natural' landscapes. Diverse areas were purposely chosen to compare landscapes not otherwise easily Comparable.

## 2. Uses of landscape graphs

The modeling approach will be used to: (1) identify common configurations within landscapes; (2) examine the connectivity of elements in landscapes; and (3) illustrate potential links with other modeling approaches. Note that the goal is to detect patterns or configurations, not the causes of them such as geomorphic heterogeneity, natural disturbance and human activity.

### 2.1. Common configurations

Graphs of the 25 diverse landscapes were examined for the presence of repeated and/or distinctive patterns or building blocks within the landscapes. Such graph patterns would represent 'configurations' of patches, corridors and matrix elements independent of landscape type or location.

Each landscape graph as a whole had a unique arrangement of nodes and linkages. Within the graphs seven distinctive patterns of nodes and linkages were identified as common, or present in more than three graphs. Three of these patterns (so-called necklace, spider, and graph cell patterns described below) were detected in > 90% of the graphs. Three additional patterns were each detected in a single landscape graph. The ten patterns of nodes and linkages identified from the graphs are named for familiar forms that they mimic.

#### 2.1.1. Description of graph patterns

The 'necklace' pattern (Fig. 2) is typical of linear elements: roads, hedgerows, powerline corridors, road verges (margins), and rivers (Figs. 3 and 4). Necklace nodes are all the same landscape element type linked together to form a pattern resembling separated beads on a necklace. Crossing linkages are common in necklaces where corridors intersect

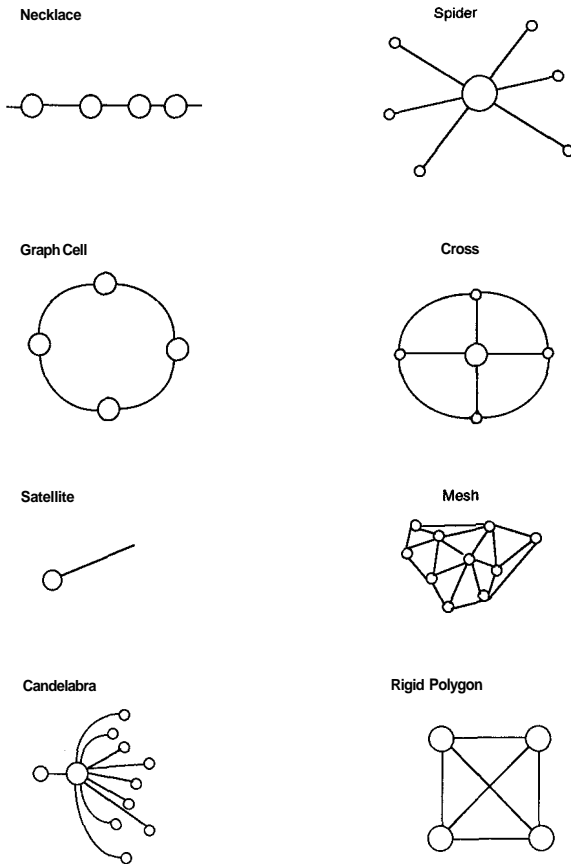

**Fig. 2.** Common and uncommon graph patterns identified from twenty-five diverse landscapes. The first seven patterns (left to right, top to bottom) were common. Three patterns were uncommon: rigid polygon, variegated necklace, and spider-satellite (see text).

(e.g., road intersections). Necklaces typically exhibit many linkages when penetrating heterogeneous space and few linkages in homogeneous landscapes. The ‘variegated necklace’ pattern looks identical to the necklace except that nodes representing different landscape elements are strung together, rather than nodes of the same type. This pattern, representing sequential zonation, was found in a graph of the Grand Canyon (USA) where elevation defined bands of different rock formations. These formations were represented by nodes strung together from the canyon top to bottom in a variegated necklace pattern.

A graph figure with a central node and  $> 4$  linkages to other landscape element nodes is

labelled a ‘spider’ (Fig. 2). The central, or spider node is often the matrix, and a large spider node element tends to have more linkages than a smaller one. Woods, grassland and fields are common spider node elements (Figs. 3 and 4). A variation on the spider pattern, the ‘spider-satellite’, was found where almost all of the nodes attached to a spider node had no other linkages. This uncommon pattern was found in a landscape where isolated wooded patches were surrounded by pastureland.

A corridor network in a landscape is represented by interconnecting necklace patterns in a graph. The component sections or units formed by this necklace network are referred to here as ‘graph cells’ (Fig. 2). In the graphs constructed, roads were the primary necklace elements delineating graph cells. Spider patterns were typically found within graph cells (Fig. 3).

The ‘cross’ pattern is an 8-linkage pattern, with four almost polar linkages off a central cross node to four surrounding nodes that are interconnected (Fig. 2). Several types of cross patterns were present in the landscape graphs. They differ in the number of element types surrounding the cross node, and whether the cross node represents a patch or corridor. For example, a field bounded by four hedgerows, or a suburban housing block surrounded by four roads would be patch-centered cross with one surrounding element type. One, two, three and four-element type patch-centered crosses were found in the landscape graphs. In contrast, corridor-centered crosses have a corridor cross node. Two, three, and four-element corridor-centered crosses were found, although two-element type crosses were most common. An example is the narrows in an hour-glass shaped field that is linked to the two large field areas and to the forest on each side.

The ‘satellite’ pattern represents an isolated patch surrounded by a single element type. The lone bog in a forest, oasis in a desert, or remnant woodland in a field are common satellites (Figs. 3 and 4). This pattern is recognized by a node with only one linkage (Fig. 2). The satellite node, in our analysis, was usually a small element in a landscape dominated by one large patch or area of matrix. In one case

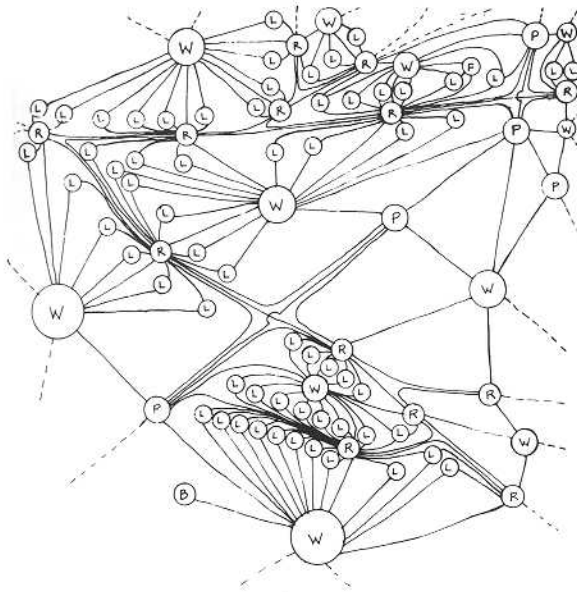
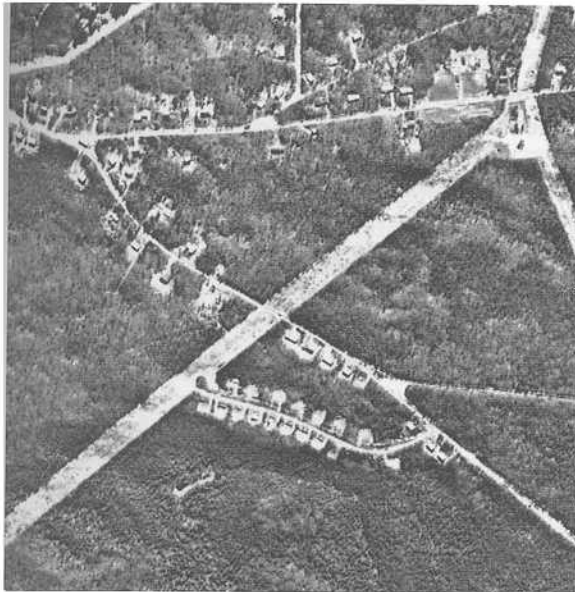

*Fig. 3.* Suburban-rural forest area represented by landscape graph model. Nodes represent landscape elements, and linkages represent common boundaries or points between two elements. Landscape elements recognized are: W-woods; F-field, L-house clearing; R-road; P-powerline; and B-bog. Dashed lines indicate probable linkages outside photograph area. The necklace pattern is illustrated by diagonal powerlines and roads; spider pattern by woods; graph cell pattern by triangular area enclosed by roads and powerlines; and the satellite pattern by isolated bog. Southeastern Massachusetts, USA (number 20 in Appendix).

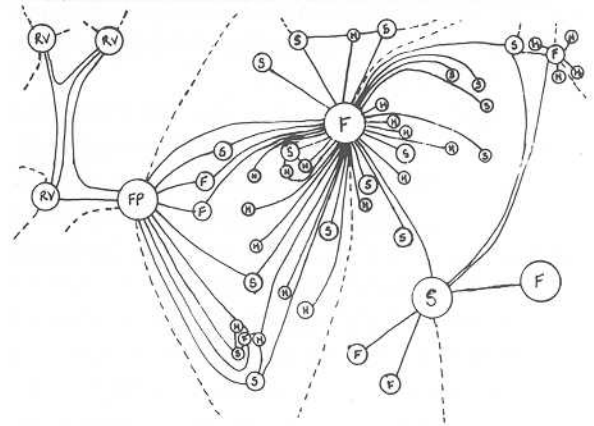
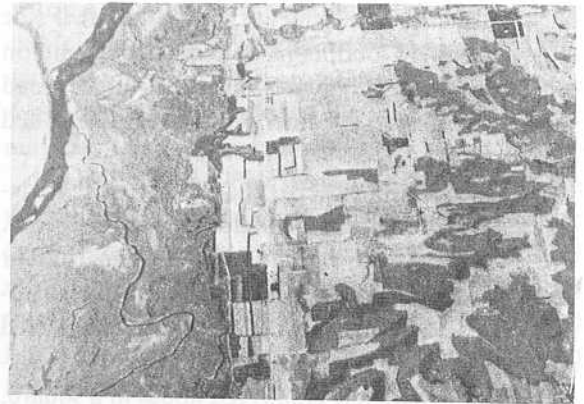

*Fig. 4.* Intersection area of three landscapes represented by landscape graph model. Landscape elements recognized are: RV-river; FP-floodplain; F-field; H-Hedgerow; and S-shrubland/woods. Spider pattern of field matrix surrounding shrubland patches is in center of graph; satellite pattern represents an isolated shrubland patch connected only to matrix, and the large interdigitated field surrounded by a band of shrubland on right; candelabra pattern represents floodplain connected only to river on left and to many elements on right. The Platte River area, Western Great Plains, USA (number 13 in Appendix).

the satellite node was large, representing an open ridge top area surrounded by a band of natural vegetation on the slopes (Fig. 4).

The 'mesh' pattern represents three or more repeating element types that are relatively similar in size. Nodes in a mesh have approximately an equal number of linkages (Fig. 2). No element in the mesh is large or connected enough to be a spider node. Meshes are common in many even-grained (low variance in grain size) agricultural landscapes.

The 'candelabra' pattern represents a central landscape element connected to many elements on

one side, and to one element type on the other side (Figs. 2 and 4). Floodplains were the most common central or candelabra nodes, but road verges (road sides), dunes, and salt water marshes also exhibited this pattern.

One uncommon pattern, in addition to the variegated necklace and spider-satellite, was detected. The 'rigid polygon' pattern occurs when four or more nodes join together at one point. For example, four fields with different crops that all touched at one point would form a rigid polygon represented by four completely connected nodes in a square. In this analysis the pattern was found only in a partially logged forest landscape of old growth, clearing, and regeneration stands.

Thus landscape graphs contain a limited number of repetitive graph patterns, of which spiders, necklaces, and graph cells predominate. In actual landscapes these represent, respectively, the following configurations: (1) a matrix or large landscape patch surrounding or adjacent to many patches; (2) a corridor bisecting the landscape; and, (3) the unit formed by a network of intersecting corridors. A focus on these and other landscape building blocks, including uncommon configurations, should enhance our understanding of the structure and functioning of landscapes, and consequently the quality of land planning and management.

### 2.1.2 Ecological and management implications.

Many of these identified patterns, representing configurations in a landscape, are useful for ecological understanding as well as landscape planning and management. Several examples for each pattern are given. While some examples are speculative, the purpose is to illustrate the richness of uses and implications of repeated configurations or patterns.

*Spider and spider-satellite.* The former represents a large patch or matrix surrounding or adjacent to many landscape patches, and the latter represents a patch entirely embedded in a matrix. Examples are a forest reserve in a suburban landscape and bogs in a boreal forest. These patterns suggest: (a) strong exchanges across patch-matrix boundaries; (b) that the matrix exerts a strong control over patches and patch species, which in turn are at risk and could easily disappear; (c) areas of

low habitat diversity, if the patches are of the same type; (d) that the matrix is subject to many influences, if the patches are of different types; (e) absence of coverts or convergency points [where three or more habitats converge, a useful spot for certain wildlife (Forman and Godron 1986)]; (f) metapopulation dynamics [frequent extinctions and some recolonizations in patches (Merriam 1990, Harms and Opdam 1990)]; and (g) genetic inbreeding in spider-satellite patches, and genetic heterogeneity for many species that are in more than one patch. Spider and spider-satellite configurations are areas in a landscape requiring careful monitoring and management.

*Necklace.* This represents a corridor penetrating the landscape. Examples are roads, hedgerows and streams. Necklaces penetrating heterogeneous space have many linkages as compared with those through a homogeneous matrix. Necklaces with many linkages exhibit: (a) more landscape resistance or a less efficient conduit for animal movement, due to exerting caution as adjacent habitats change; (b) more microhabitat heterogeneity and more edge species; and (c) less of a barrier effect for an animal, *i.e.*, greater ease in finding a suitable crossing spot, such as natural vegetation on both sides of a road. Necklaces with few linkages exhibit: (a) less landscape resistance; (b) microhabitat homogeneity (c) and either extreme landscape resistance for an animal seeking an appropriate crossing point, or rapid exchange if the habitat is appropriate, *e.g.*, corn field to corn field for pest spread. Management should often favor necklaces with many linkages to minimize species isolation in a landscape, enhance populations of 'two-plus species' (animals requiring or using two or more habitats), and provide coverts (contingency points) for certain wildlife using three adjacent habitats.

*Graph Cell.* This represents a section or unit in a network of necklaces. Graph cells may be formed by one necklace type, *e.g.*, a road network, or two or more necklace types, *e.g.*, roads and powerlines (as in Fig. 3). Landscape grain is typically measured by the mean area or diameter of the patches and corridors in a landscape (Forman and Godron 1986). One-necklace-type graph cells can also be a

measure of grain at a somewhat coarser scale, and two-necklace-type graph cells can be a measure of grain at a still coarser scale. It would be interesting to interpret ecologically the means and variances of grain at these nested scales. For example, decreasing graph cell size (or landscape grain), appears to correlate with increasing human population density as road networks, in particular, become more dense. Graph cells, just as for any circuit, offer optional routes for animals and people between two points in a corridor system. Graph cells are good candidates for individual or local management, because of the clear boundaries and the normally good access from all sides.

*Candelabra.* This represents an elongated landscape element separating one element on one side from many elements on the other side. Examples are a wetland floodplain separating a river from many adjacent upland land uses, and a green belt separating a town from diverse adjoining land uses beyond. The elongated landscape element, or central node, functions as a narrows or bottleneck or filter. In the floodplain case, nutrients from the upland must pass through the wetland to enter the river, or an animal from the river area must cross the wetland to reach the upland resources. The candelabra pattern gradually disappears as the floodplain loses its connectivity and becomes subdivided into small land uses. The central node of a candelabra indicates a landscape element requiring special management focus.

*Mesh.* This represents at least three landscape element types in which patches are of approximately equal size. Crop fields of three types in farmland, and forest patch cuts of different regeneration ages are examples. A mesh indicates a: (a) landscape under intensive management where no one patch type predominates; (b) abundance of coverts; (c) paucity of corridors (and no graph cells) dividing up the landscape; and (d) broad scale homogeneity of fine-scale patch clusters repeated over the landscape. A mesh may indicate an area of a landscape where sustainability is unlikely and a management change is warranted.

*Satellite.* This represents a lone patch surrounded by matrix or a large patch. The satellite may indicate: (a) a patch or patch species in danger of disap-

pearing; (b) genetic inbreeding in the lone patch, and (c) the necessity of an animal to be compatible with the matrix in order to enter or leave the patch. Again, monitoring and possibly active management may be indicated by a satellite.

*Rigid Polygon.* This represents four or more patches joining at a point. In such a configuration: (a) the point is a covert; (b) a funnel effect of animal movement (slowly due to behavioral caution) through the point is likely; and (c) water and wind fluxes (accelerated due to the Bernoulli effect) through the point are likely.

*VariigatedNecklace.* This represents banding or zonation of landscape elements, such as from lake to upland, or along a mountain slope. The configuration: (a) is usually along an environmental gradient; and (b) has the end node embedded in a ring or donut shaped patch (the penultimate node). As in several preceding cases, special monitoring, planning and management typically is appropriate for the distal nodes of a variegated necklace.

In short, the ecological implications pinpointed suggest a wide range of ecological insights possible from identifying configurations in a landscape. The management implications noted suggest areas within a landscape warranting special care or focus, or even change in management, independent of landscape type.

## 2.2. Connectivity

Connectivity is considered a measure of the strength of the relationships described by the graph (Ore 1963, Taaffe and Gauthier 1973, Wilson 1979) and is one of the most common measurements. Ecologically, high connectivity implies much interaction or movement of animals, plants, heat energy, water, and materials among elements (Forman and Godron 1986, Turner 1987b, Forman 1991).

A common measure of connectivity is the 'degree of a node' in mathematics, or beta index in transportation geography, which is simply the number of linkages connected to a given node. In landscape graphs, where linkages represent adjacencies, the degree of a node of any given landscape element is an indication of how accessible that element is, as

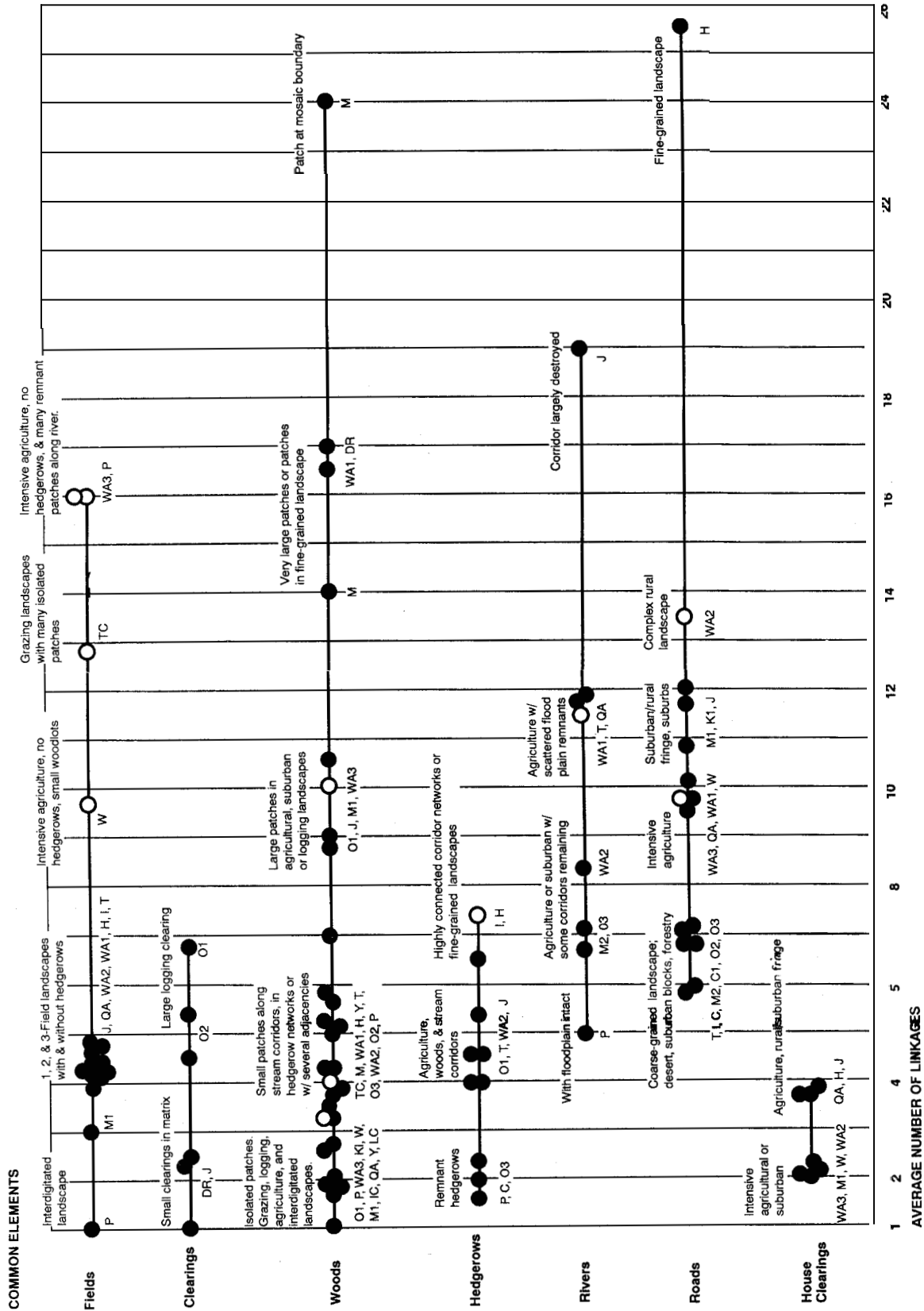

Fig. 5. Connectivity of common elements in diverse landscapes. Brief interpretations are given above points, and landscape abbreviations (see Appendix) below points. An open circle around a point indicates the presence of high variability (variance > mean).

well as its overall relative influence in the landscape (Bruce G. Marcot, personal communication). The degree of a node was determined for each node in the 25 landscape graphs, and the mean number of linkages calculated for each element type in each graph (see Appendix and Fig. 5). Although a full statistical analysis of this data set is beyond the scope of this paper, several results illustrating promising uses of graph models are noted.

As might be expected, larger elements (relative to others in the graph) had more linkages than smaller ones. However, small elements were well connected if they had a linear shape or were in a finely dissected landscape (*e.g.*, a pond surrounded by many land uses). Roads and rivers were the most connected elements (grand means of 9.1 and 10.1 respectively, versus 2.8 to 6.5 for other element types) (Figs. 3 and 5). Rivers with intact floodplains (not dissected or fragmented) and roads with continuous verges exhibited low connectivity, whereas the adjacent floodplain or verge was well connected (*e.g.*, Fig. 4). Linear shaped hedgerows were also well connected, especially when they formed an interconnected network.

Woods elements (Fig. 5) were the most variable in relative size and connectivity. Isolated patches exhibited one linkage, and small patches adjacent to stream corridors or in hedgerow networks had more. Large wooded patches that were not the matrix were well connected to other landscape element types, but rarely to each other. Such patches had more connections than a forest matrix of logged clearing and forest stands. The highest degree of the node for woods was found at the transition mosaic zone between two forest types, where each of the two large intersecting patches were spider-satellites.

Two element types, fields and house clearings, exhibited a relatively constant number of linkages. Fields almost always had four linkages (Fig. 5). Exceptions on the high side indicated intensive cultivation areas without hedgerows, but with remnant patches (*e.g.*, Fig. 4). Pastureland had many linkages due to small clusters of remaining trees. House clearings (the openings around buildings) typically had only two linkages (Fig. 5), to a road and to the surrounding element type (*e.g.*, Fig. 3). Only in cer-

tain agricultural locations where the farmer surrounded the home with diverse resources, and in the suburban/rural fringe where house clearings were at the juncture of two landscape types, were house clearings better connected.

The degree of a node is a simple measure and only quantifies adjacency (*e.g.*, a patch two-steps away is not considered). Other measures of connectivity may be applied to graphs (Taaffe and Gauthier 1973, Haggett *et al.* 1977, Rugg 1979, Wilson 1979, Forman and Godron 1984, 1986). Measures of connection in food webs are also available (*e.g.*, Sugihara 1984, Cohen 1990). Elements may be examined for how frequently they are connected to a particular type. Also, the robustness of the graph may be evaluated by examining linkage and node connectivity (*e.g.*, the number of nodes or linkages that must be removed in order to disconnect the graph). This measure allows the connectivity of the entire landscape to be assessed.

For example, in the two graphs illustrated, woods are the most connected landscape element type in Fig. 3, while fields are in Fig. 4. In Fig. 3, home lots are the least connected, and 100% of the lots are connected to woods and to roads. Woods are connected to every landscape element type. In contrast, in Fig. 4, shrubland/woods are the least connected element type, and 100% of them are connected to fields. The graph in Fig. 4 is not very robust. Removal of the floodplain (FP), large field (F), or large shrubland (S) node would disconnect the graph into two graphs. The landscape pattern of Fig. 3 is more robust as removal of any node does not severely affect the graph structure.

This brief assessment emphasizes that some landscape elements are inherently better connected than others. Of special interest is the high connectivity exhibited by linear elements, suggesting substantially more influence on the landscape than a measure of relative area would indicate. The connectivity analysis also emphasizes that some landscape element types have a relatively constant number of connections, irrespective of context. This reinforces the conclusion in Section 2.1. on common configurations, that a landscape, like other objects, is composed of distinct spatial patterns or building blocks that may be combined in different ways.

2.3. Additional uses

In addition to the diverse measures and applications provided by the field of graph theory, a graph theoretic landscape graph is a structure to which other modeling approaches may be applied. For example, to better understand fluxes, systems dynamics models, connectivity matrices and percolation theory may be applied. Hierarchy theory may be useful for studying the internal structure of nodes, and insights into landscape management and change may be possible through further pattern analysis. These additional uses are briefly described to suggest the richness of the landscape graph approach.

2.3.1. Systems dynamics

Systems dynamics is a modeling paradigm to which the landscape graph is particularly well suited. Systems models are conceptualized as a set of compartments, with flows between them. The landscape graph may be used as the skeletal structure for such a model, where nodes correspond to compartments and linkages to flows. Because the landscape graph includes all element types whether patch, matrix or corridor, it is a complete description of the entire landscape as a series of interconnected compartments, where flows occur as a result of element adjacencies.

The usefulness of the landscape graph as a systems dynamics framework may be illustrated by a simple model created using STELLA II® software. Consider the graph of a landscape where a Woods is adjacent to a Field which in turn contains a Woods Patch. In the graph, linkage length is proportional to boundary length, where the Woods/Fields boundary is twice as long as the Field/Woods Patch boundary.

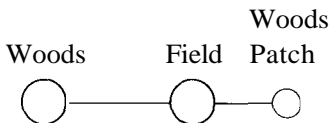

Systems dynamics flows occur according to an equation expressing the rate of flow between compartments in terms of the values of compartments, parameters and other variables in the model. As-

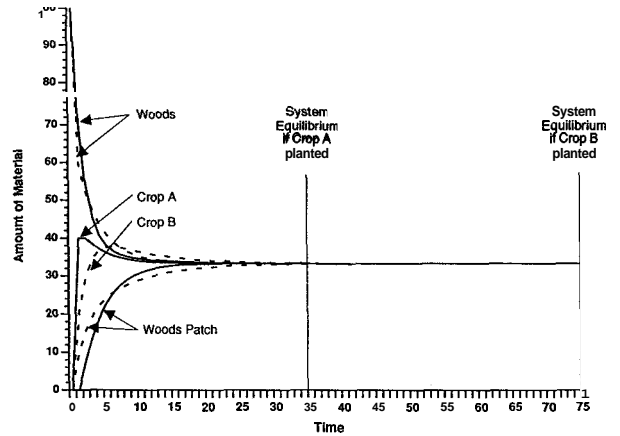

Fig. 6. Systems dynamics model results showing quantity of material in each node per unit time. Solid lines show quantity in Woods, Field and Woods Patch if Crop A is planted; dashed lines show quantity in these elements if Crop B is planted. See text for initial values, exchange rates and questions.

sume material moves between the nodes in the graph above according to a diffusion type dispersal equation (modified from Hastings 1990): Dispersal at time  $t = (\text{Rate of exchange between nodes } a \text{ and } b) \times (\text{Amount of material in } b - \text{Amount of material in } a)$ . The dynamics of each node (or compartment) is governed by a differential equation which is formed from the sum of the inflows into the compartment minus the outflows from it. Thus: Amount of Material in Node at time  $t = (\text{Amount of Material in Node at time } t-\Delta t) + [(\Delta t) \times (\text{Flow into the Node} - \text{Flow out of the Node})]$ , where  $\Delta t$  is the time interval for calculations used to approximate the differential equation curve.

In the example, assume that a material (species, pollen, etc.) exists only in the Woods initially (Woods initial value = 100; Field and Woods Patch initial values = 0). A farmer wishes to compare the effect that planting different crops in the Field has on the movement of the material. If Crop A offers half the landscape resistance that Crop B does, and exchange rates are proportional to boundary length, then the following exchange rates may be assumed: Woods and Crop A = .40; Crop A and Woods Patch = .20; Woods and Crop B = .20; Crop B and Woods Patch = .10). The results of running of this systems dynamics model show that with both planting options the quantity of material

in the Field will initially overshoot (more and sooner with Crop A than B) before reaching equilibrium (Fig. 6). With Crop A equilibrium of the system will be reached in 34 days, whereas with Crop B, 74 days are required.

This simple systems dynamics model may be enhanced by including other parameters important to understanding the system such as birth and death rates (Andow *et al.* 1990, Henein and Merriam 1990, Hastings 1990), and by modeling more complex landscapes. As graph complexity increases and flow parameters become less well understood, the link with systems dynamics models becomes increasingly useful because of the limited requirement to define quantitative terms. It is indeed possible to specify complex and realistic models without entering a single equation, simply by defining relationships (Robertson *et al.* 1991).

### 2.3.2. Connectivity and accessibility matrices

Matrices may be constructed from landscape graphs to more fully understand the connectivity or accessibility of elements in the graph (Alan R. Johnson, personal communication, Taaffe and Gauthier 1973). A connectivity matrix (C), where nodes are numbered and listed in both the columns and rows of the matrix, may be used to determine direct and indirect connectivity. For example, assuming six nodes, a 6 by 6 matrix is constructed, where '0' indicates no direct linkage and '1' a direct linkage between landscape elements (nodes). When the matrix is squared, '1's' appear where there are two-step paths between a given pair of nodes or landscape elements. Cubed matrices identify elements that are linked by three steps, etc. The connectivity matrix may be useful to determine linkage or interaction between non-adjacent elements, such as a bird feeding in two woods separated by a field.

The accessibility matrix (A) is the sum of the connectivity matrix (C) and all matrices that enumerate indirect paths between nodes of the graph. Thus,  $A = C + C^2 + C^3 + \dots + C^n$ , where 'n' is equal to the maximum number of steps to traverse the graph. Accessibility matrices may be useful for understanding landscape resistance or animal and plant dispersion across a landscape (Forman and

Godron 1986). There are many other possible matrix applications.

### 2.3.3. Percolation theory

Percolation theory may be useful to landscape graphs. Through a simple application of the percolation backbone, graphs may be used to determine circuitry, or the number of optional routes in a landscape (Alan R. Johnson, personal communication, Stanley 1977, Haggett *et al.* 1977, Stauffer 1985, Forman and Godron 1986, Gardner *et al.* 1989). For example, by isolating from the graph the element types that a species is likely to traverse, and establishing initial and terminal travel nodes, all nodes in between may be classified as either: (a) nodes through which the species must pass, (b) nodes through which the species may pass, or (c) dead ends, which do not lead toward the terminal node. From this analysis, the most direct route (or backbone), and number of optional circuits (paths), available to travel across the landscape by going through only compatible landscape elements is revealed. Once outlined, paths may be visually examined for other factors, such as the number of element types adjacent to the path.

### 2.3.4. Directionality

A graph may be used to model movements of species, or disturbances such as fire (Turner 1987b). By assigning directionality to the linkages (essentially thinking of them as vectors) and resistance factors to the nodes (Forman and Godron, 1986, Harms and Opdam 1990), net movement may be calculated. It may also be possible to make assumptions about linkage directionality and node resistance from the relative suitability of adjacent elements, or their spatial configuration.

### 2.3.5. Hierarchy theory

Hierarchy theory may be applied to the graphs to model the internal structure of nodes (Allen *et al.* 1984, O'Neill *et al.* 1986, 1989). For example, a node may represent an entire valley bottom at one scale; however, nested within that node is a sub-set of channels, stream banks, wetlands, and well-drained soils. This application may be useful where the spatial configuration at the finer scale is impor-

tant to interactions at the broader scale, or vice versa.

### 2.3.6. Management options

Landscape graphs may also be manipulated to identify and resolve ‘what if’ type management options (Gross and Dykstra 1989). By removing or changing elements, a new graph is created. This graph may be compared with the original for pattern, connectivity, circuitry, movement, or other ecological measures.

### 2.3.7. Landscape change

Finally, landscape graphs should be useful in identifying and comparing the patterns produced by different processes of landscape change. Thus the spatial changes produced by deforestation, desertification and suburbanization are readily compared, as well as a particular process in different parts of the world. The connectivity and interaction dimension of landscape graph modeling would complement dynamic models of spatial structure, such as for the 50 years of landscape change due to many processes in Georgia (USA) (Turner 1988, Odum and Turner 1990), or the geometric models of landscape and ecological changes produced by different logging regimes (Franklin and Forman 1987, Hansen *et al.* 1992).

## Conclusion

The graph construction method outlined is a way of describing landscape structure. It is also possible to model landscape element size, connectivity, and direction of flow. This makes the method potentially useful for ecological modeling of landscape functioning and future changes that result from interactions between adjacent ecosystems. As a management tool and disturbance evaluator, its value is based on the ready comparison of diverse areas by reducing the landscape to a common structure. Thus land managers can compare the pattern and expected ecological effect of proposed landscape modifications.

One of the most important characteristics pinpointed in drawing graphs is the importance of

linear elements. The graphs drawn depict highly connected linear elements which divide the landscape into component cells or units. The importance of linear elements in the graph contrasts sharply with ecologists’ traditional focus on characteristics within a patch or the matrix. Similarly, the attention given to linear elements in landscape graphs differs from the results of commonly-used raster GIS systems, where each cell expresses only the most dominant element type present, and therefore smaller corridors (country roads, hedgerows, etc.) easily disappear (Burrough 1986). Linear elements, such as roads, are major movement conduits and sources of pollution and energy consumption, and many animals tend to avoid crossing even narrow roads (Lyon 1983; Forman 1991).

The flexibility of the basic landscape graph modeling approach permits many additional objectives or variables, including mathematical descriptions, to be incorporated. In a patchy landscape with few corridor intersections, each corridor segment could be determined by adjacent land use. Thus in Fig. 1c, two H nodes would be present, highlighting the ecological difference of being next to woods versus beanfield. Other examples include: adjusting node size to accurately reflect the area covered by the element; using the length of the linkage to describe the length of the common boundary between elements; using line thickness or different line types to reflect the quality of linkages (*e.g.*, quantity of fluxes between elements); varying the linkage to reflect the fractal dimension of a patch edge; and a ‘look-up’ table, like the periodic table of elements, to describe other ecological and land-use characteristics of the landscape elements. In the future one might envision graphs with databases behind each node and linkage, describing landscape relations based upon size, flow, and other measurable characteristics.

Finally, drawing landscape graphs requires one to carefully examine spatial juxtaposition and relationships. This in itself is an important step, if the relationship between the spatial configuration of patches, corridors and matrix in a land mosaic, and the movement and change of organisms, energy and materials, is the central paradigm for understanding the ecology of landscapes.

## Acknowledgments

We are pleased to thank Alan R. Johnson, Michael W. Binford, and Dennis P. Dykstra for helpful information and comments on the manuscript, and George Sugihara, Patrick Kangas, and Bruce Marcot for suggesting the promise of applying graph theory. This research was partially sponsored by the Canada Mortgage and Housing Corporation, The O'Brien Foundation, and the Urban Land Institute.

## References

- Allen, T.F.H., O'Neill, R.V. and Hoekstra, T.W. 1984. Inter-level Relations in Ecological Research and Management: Some Working Principles from Hierarchy Theory, USDA Forest Service: General Technical Report RM-110.
- Andow, D.A., Kareiva, P.M., Levin, S.A. and Okubo, A. 1990. Spread of invading organisms. *Landscape Ecology* 4: 177–188.
- Baker, W.L. 1989. A review of models of landscape change. *Landscape Ecology* 2: 111–133.
- Burke, I.C., Schimel, D.S., Yonker, C.M., Parton, W.J., Joyce, L.A. and Lauenroth, W.K. 1990. Regional modeling of grassland biogeochemistry using GIS. *Landscape Ecology* 4: 45–54.
- Burrough, P.A. 1981. Fractal dimensions of landscapes and other environmental data. *Nature* 294: 240–242.
- Burrough, P.A. 1986. Principles of Geographic Information Systems for Land Resources Assessment. Oxford: Oxford University Press.
- Caswell, H. 1976. Community structure: A neutral model analysis. *Ecological Monographs* 46: 327–354.
- Christaller, W. 1933. Die Zentralen Orte in Suddentschland. Jena: Fischer.
- Cohen, J.E. 1978. Food Webs and Niche Space. Princeton, New Jersey: Princeton University Press.
- Cohen, J.E., Briand, F. and Newman, C.M. 1990. Community Food Webs: Data and Theory. New York: Springer-Verlag.
- Couclelis, H. 1985. Cellular worlds: A framework for modeling micro-macro dynamics. *Environment and Planning A* 17: 585–596.
- Dale, M. 1985. Graph theoretical methods for comparing phytosociological structures. *Vegetatio* 63: 79–88.
- DeAngelis, D.L., Waterhouse, J.C., Post, W.M. and O'Neill, R.V. 1985. Ecological modelling and disturbance evaluation. *Ecological Modeling* 29: 399–419.
- Dykstra, D.P. 1981. Spatial integrity in forest planning models. *In* Proceedings of the Forest Industry Workshop – 7-11. Edited by P. Uronen. International Institute for Applied Systems Analysis. A-2361 Laxenburg, Austria. CP-81-3.
- Fahrig, L. and Merriam, G. 1985. Habitat patch connectivity and population survival. *Ecology* 66: 1762–1768.
- Forman, R.T.T. 1979. The New Jersey Pine Barrens, an ecological mosaic. *In* Pine Barrens: Ecosystem and Landscape. Edited by R.T.T. Forman. New York: Academic Press, pp. 569–585.
- Forman, R.T.T. 1991. Landscape Corridors: From Theoretical Foundations to Public Policy. *In* Nature Conservation: The Role of Corridors. Edited by D.A. Saunders and R.J. Hobbs. Chipping Norton, Australia: Surrey Beatty. pp. 71–84.
- Forman, R.T.T. and Godron, M. 1984. Landscape ecology principles and landscape function. *In* Proceedings of the First International Seminar on Methodology in Landscape Ecological Research and Planning. Edited by J. Brandt and P. Agger. Roskilde, Denmark: Roskilde Universitetsforlag GeoRuc. Vol. 5, pp. 4–14.
- Forman, R.T.T. and Godron, M. 1986. Landscape Ecology. New York: John Wiley.
- Franklin, J.F. and Forman, R.T.T. 1987. Creating landscape patterns by forest cutting: ecological consequences and principles. *Landscape Ecology* 1: 5–18.
- Gardner, R.H., Milne, B.T., Turner, M.G. and O'Neill, R.V. 1987. Neutral models for the analysis of broad-scale landscape pattern. *Landscape Ecology* 1: 19–28.
- Gardner, R.H., O'Neill, R.V., Turner, M.G. and Dale, V.H. 1989. Quantifying scale-dependent effects of animal movement with simple percolation models. *Landscape Ecology* 3: 217–227.
- Godron, M. 1966. Application de la theorie de l'information a l'etude de l'homogeneite et de la structure de la vegetation. *Oecologia Plantarum* 1: 187–197.
- Gross, T.E. and Dykstra, D.P. 1989. Scheduling Timber Harvests for Wildlife, Allowing Well-defined Violations to Age Class Nonadjacency Constraints. *In* Multiresource Management of Ponderosa Pine Forests. USDA Forest Service General Technical Report RM-185.
- Haggett, P., Cliff, A.D. and Frey, A. 1977. Locational Analysis in Human Geography. New York: Wiley.
- Hansen, A.J., Urban, D.L. and Marks, B. 1992. Avian community dynamics: The interplay of landscape trajectories and species life histories. *In* Landscape Boundaries: consequences for Biotic Diversity and Ecological Flows. Hansen, A.J. and DiCastrì, F. eds. New York, Springer-Verlag. pp. 170–195.
- Harary, F. 1972. Graph Theory. Reading, Massachusetts: Addison Wesley.
- Harms, W.B. and Opdam, P. 1990. Woods as habitat patches for birds: Application in landscape planning in the Netherlands. *In* Changing Landscapes: An Ecological Perspective. Edited by I.S. Zonneveld and R.T.T. Forman. Springer-Verlag: New York. pp. 73–97.
- Hastings, A. 1990. Spatial heterogeneity and ecological models. *Ecology* 71: 426–428.
- Henein, K. and Merriam, G. 1990. The elements of connectivity where corridor quality is variable. *Landscape Ecology* 4: 157–170.
- High Performance Systems, Inc. 1990. STELLA II®.

- Johnson, L. 1990. Analyzing spatial and temporal phenomena using geographical information systems: A review of ecological applications. *Landscape Ecology* 4: 31–43.
- Kozova, M., Smitalova, K. and Vizyova, A. 1986. Use of measures of network connectivity in the evaluation of ecological landscape stability. *Ekologia (Czechoslovakia)* 5: 187–202.
- Levin, S.A. 1976. Population dynamic models in heterogeneous environments. *Annual Review of Ecology and Systematics* 7: 287–310.
- Levins, R. 1975. Evolution in communities near equilibrium. *In: Ecology and Evolution of Communities*. Edited by M.L. Cody and J.M. Diamond. Cambridge, Massachusetts: Belknap Press. pp. 16–50.
- Lowe, J.C. and Moryadas, S. 1975. *The Geography of Movement*. Boston: Houghton Mifflin.
- Lyon, J. 1983. Road density models describing habitat effectiveness for elk. *Journal of Forestry* 81: 592–595.
- Merriam, G. 1990. Ecological processes in the time and space of farmland mosaics. *In Changing Landscapes: An Ecological Perspective*. Edited by I.S. Zonneveld and R.T.T. Forman. New York: Springer-Verlag. pp. 121–133.
- Milne, B.T. 1988. Measuring the fractal geometry of landscapes. *Applied Mathematics and Computation* 27: 67–79.
- Milne, B.T., Johnston, K.M. and Forman, R.T.T. 1989. Scale-dependent proximity of wildlife habitat in a spatially neutral Bayesian model. *Landscape Ecology* 2: 101–110.
- O'Neill, R.V., Johnson, A.R. and King, A.W. 1989. A hierarchical framework for the analysis of scale. *Landscape Ecology* 3: 193–205.
- O'Neill, R.V., Milne, B.T., Turner, M.G. and Gardner, R.H. 1988. Resource utilization scales and landscape pattern. *Landscape Ecology* 2: 63–69.
- O'Neill, R.V., DeAngelis, D.L., Waide, J.B. and Allen, T.F.H. 1986. *A Hierarchical Concept of Ecosystems*. Princeton, N.J.: Princeton University Press.
- Odum, E.P. and Turner, M.G. 1990. The Georgia landscape: a changing resource. *In Changing Landscapes: An Ecological Perspective*. Edited by I.S. Zonneveld and R.T.T. Forman. New York: Springer-Verlag. pp. 137–164.
- Odum, H.T. 1983. *Systems Ecology: An Introduction*. New York: John Wiley.
- Ore, O. 1963. *Graphs and Their Uses*. New York: Random House.
- Pastor, J. and Broschart, M. 1990. The spatial pattern of a northern conifer-hardwood landscape. *Landscape Ecology* 4: 55–68.
- Pickett, S.T.A. and White, P.S. eds., 1985. *The Ecology of Natural Disturbance and Patch Dynamics*. New York: Academic Press.
- Risser, P.G., Karr, J.R. and Forman, R.T.T. 1984. *Landscape Ecology: Directions and Approaches*. Illinois Natural History Survey, Champaign, Illinois. Special Publ. 2.
- Roberts, D.W. 1989. Analysis of forest succession with fuzzy graph theory. *Ecological Modelling* 45: 261–274.
- Robertson, D., Bundy, A., Muetzelfeldt, R., Haggith, M. and Uschold, M. 1991. *Eco-Logic: Logic-Based Approaches to Ecological Modeling*. Cambridge, MA: The MIT Press.
- Rouvray, D.H. 1973. The search for useful topological indices in chemistry. *American Scientist* 61: 729–735.
- Rugg, D.S. 1979. *Spatial Foundations of Urbanism*. Dubuque, Iowa: Wm. C. Brown Company.
- Shugart, H.H., Jr. and Seagle, S.W. 1985. Modeling forest landscapes and the role of disturbance in ecosystems and communities. *In The Ecology of Natural Disturbance and Patch Dynamics*. Edited by S.T.A. Pickett and P.S. White. New York: Academic Press. pp. 353–368.
- Sklar, F.H., Costanza, R. and Day, J.W., Jr. 1985. Dynamic spatial simulation modeling of coastal wetland habitat succession. *Ecological Modeling* 29: 261–281.
- Stanley, H.E. 1977. Cluster shapes at the percolation threshold: an effective cluster dimensionality and its connection with critical-point exponents. *Journal of Physics A – Mathematical and General* 10: L211–L215.
- Stauffer, D. 1985. *Introduction to percolation theory*. London: Taylor and Francis.
- Sugihara, G. 1983. Holes in niche space: A derived assembly rule and its relation to intervality. *In Current Trends in Food Web Theory: Report on a Food Web Workshop*. Edited by DeHuxlis, Post and G. Sugihara. Oak Ridge, Tennessee: Oak Ridge National Lab, Publ.-5983, pp. 25–35.
- Sugihara, G. 1984. Graph Theory, Homology and Food Webs. *In Proceedings of Symposia in Applied Mathematics*. American Mathematical Society 30: 83–101.
- Taaffe, E.J. and Gauthier, H.L., Jr. 1973. *Geography of Transportation*. Englewood Cliffs, New Jersey: Prentice-Hall.
- Turner, M.G. 1987a. Spatial simulation of landscape changes in Georgia: A comparison of three transition models. *Landscape Ecology* 1: 29–36.
- Turner, M.G. 1987b. *Landscape Heterogeneity and Disturbance*. New York: Springer-Verlag.
- Turner, M.G. 1988. A spatial simulation model of land use changes in Georgia. *Applied Mathematics and Computation* 27: 39–51.
- Turner, M.G. and Gardner, R.H. eds. 1991. *Quantitative Methods for Analyzing Landscape Pattern*. New York: Springer-Verlag.
- Wegner, J.F. and Merriam, G. 1979. Movements by birds and small mammals between a wood and adjoining farmland habitats. *Journal of Applied Ecology* 16: 349–358.
- Wiens, J.A. and Milne, B.T. 1989. Scaling of 'landscapes' in landscape ecology, or, landscape ecology from a beetle's perspective. *Landscape Ecology* 2: 87–96.
- Wilson, R.J. 1979. *Introduction to Graph Theory*. New York: Academic Press.
- Zeigler, B.P. 1976. *Theory of Modeling and Simulation*. New York: John Wiley.

## APPENDIX: The Landscapes Modeled with Graph Theory

Landscapes are listed in general order of increased human population density. A linkage indicates that two elements share a

common boundary or point; see text. Abbreviations after location titles are used in Fig. 4. The landscape elements identified are listed along with their number (preceding the hyphen) and the mean number of linkages (following the hyphen).

1. *Southwestern Montana, USA (M)*. Mosaic boundary between forest & burned area.  
(Continuous Forest 1-14.0; Continuous Regeneration Forest 1-24.0; Forest Patch 12-3.5; Regeneration Patch 8-3.8; Mixed Patch 14-3.9).
2. *Southern Labrador, Canada (LC)*. String bog and spruce forest.  
(Open Water 2-1.5; Bog Patch 8-5.3; Spruce Forest 9-2.6).
3. *Yellowstone National Park, USA (Y)*. Forest and grassland.  
(Coniferous Woods 9-3.3; Deciduous Woods 1-4.0; Grassland 7-4.1).
4. *Grand Canyon, USA (G)*. Alternating rock formations with elevation.  
(Formation A 1-2.0; Formation B 1-2.0; Formation C 1-2.0; Formation D 1-2.0).
5. *The Llanos, Southern Colombia (TC)*. Gallery forest and grassland.  
(Gallery Forest 23-3.3; Grassland 3-12.7).
6. *Western Oregon, USA (01)*. Coniferous forest with patch cutting.  
(Forest Patch 4-8.8; Clearing Patch 4-6.8; Forest Corridor 6-4.0; Clearing Corridor 7-4.0; Remnant Tree 2-1.0).
7. *Western Oregon, USA (02)*. Coniferous forest with logged & regenerating patches.  
(Old Growth 5-5.8; Regrowth Stand 5-5.2; Regeneration Clearing 5-5.4; Recent Clear-cut 4-4.5; Road 8-6.9).
8. *Dominican Republic (DR)*. Tropical rain forest with shifting cultivation.  
(Woods 1-17.0; Recent Clearing 6-2.7; Regenerating Clearing 5-1.0; Clearing Corridor 6-4.5).
9. *Eastern Texas, USA (T)*. Dry land with rivers, dams, fields, & riparian vegetation.  
(Dry Land 6-11.3; Irrigated Field 7-3.9; Head Pond 3-13.0; River 7-11.7; Riparian Vegetation Patch 13-4.2; Riparian Vegetation Corridor 25-4.5; Dam 2-9.5; Road 11-5.9).
10. *Puerto Rico (PR)*. Small islands surrounded by Caribbean Sea.  
(Island 7-1.0; Sea 1-7.0).
11. *Near Kerman, Iran (KI)*. Desert with scattered oasis villages.  
(Desert 4-7.3; Oasis 21-2.0; Road 4-11.8).
12. *Western New South Wales, Australia (WA3)*. Eucalypt forest with grazed clearings.  
(Large Woods 3-10.7; Field (grazing) 3-16.0; Rock Outcrop 1-4.0; Remnant Tree Patch 32-1.9; Road 3-9.7; House Clearing 1-2.0).
13. *Western Great Plains, USA (P)*. Interdigitated field & natural vegetation with river.  
(Interdigitated Field 3-1.0; Interdigitated Shrubland 1-7.0; Field 3-16.0; Remnant Shrubland 17-1.9; Hedgerow 15-1.5; Flood Plain 1-14.0; River 3-5.0).
14. *Central New South Wales, Australia (WAI)*. Two-field type agriculture and river system.  
(Large Woods 2-16.5; Remnant Woods 12-4.2; Field Type A 40-4.1; Field Type B 33-4.2; Road 12-9.6; River 10-11.5).
15. *Central Indiana, USA (I)*. Cultivated fields with hedgerows.  
(Field 9-4.3; Hedgerow 8-6.5; Road Verge 2-8.0; Road 2-6.0).
16. *Central New Jersey, USA (J)*. Cultivated fields, hedgerows and a stream.  
(Field 13-4.7; Hedgerow 14-5.4; Road 1-12.0; House Clearing 7-3.9; Forest Patch 4-9.0; Clearing 2-2.5; Stream Corridor 1-19.0).
17. *Central New South Wales, Australia (WA2)*. Three-field type agriculture and drainage courses.  
(Field A 13-4.4; Field B 8-4.3; Field C 16-4.8; Road 7-13.4; House Clearing 7-2.3; Drainage Course 6-8.3; Riparian Corridor 22-4.5; Riparian Patch 12-5.1).
18. *Southeast Queensland, Australia (QA)*. Two-field type agriculture and river.  
(Field A 21-4.5; Field B 16-4.8; Road 9-9.7; House Clearing 10-3.7; River 4-11.8; Floodplain Remnant 4-2.8).
19. *Southern Wisconsin, USA (W)*. Pastureland with scattered woods.  
(Grazing Field 10-9.7; Road 18-10.1; House Clearing 47-2.2; Woods Patch 16-2.1).
20. *Southeastern Massachusetts, USA (MI)*. Oak-pine forest with individual houses along roads.  
(Road 12-10.8; House Clearing 64-2.1; Woods 11-10.0; Powerline 5-6.8; Field 1-3.0; Lake 1-1.0).
21. *Western Oregon, USA (03)*. Suburban-rural fringe with wheat fields & housing.  
(Housing Block 5-4.2; Field 10-6.8; Wood 4-5.0; Remnant Hedgerow 12-2.4; Stream 8-7.1; Pond 3-4.0; Road 6-7.2).
22. *Central Colorado, USA (C)*. Suburban fringe with housing surrounded by roads.  
(Housing Block 11-4.6; School Block 1-6.0; Road 16-6.1; Hedgerow 1-2.0).
23. *Northern Honduras (H)*. Edge of rural town: houses, gardens & roads.  
(Road 4-25.5; Field 19-4.3; Hedgerow 7-7.4; Tree Patch 6-5.7; House Clearing 35-3.7).
24. *Suburban Chicago, Illinois, USA (CI)*. Urban districts and roads.  
(Residential 2-6.5; High School 1-4.0; Industrial 1-4.0; Retail 1-6.0; Road 7-7.1).
25. *Boston, Massachusetts, USA (M2)*. Urban districts, roads, river & parks.  
(Park 4-3.5; Residential 3-5.3; Financial 1-7.0; Business 4-4.8; River 3-6.7; Road 8-6.9).